

TUNNEL HEADING AND LOADING MACHINE

ITC 120 - F2



- Excavation boom equipment with rock breaker / bucket combination for tunnelling in soft and medium hard ground conditions by using bucket and hydr. hammer
- Diesel drive 74 kW
- Electric drive 55 kW
- Operating weight approx. 23,3 t

Made in Germany by



ITC 120 F2

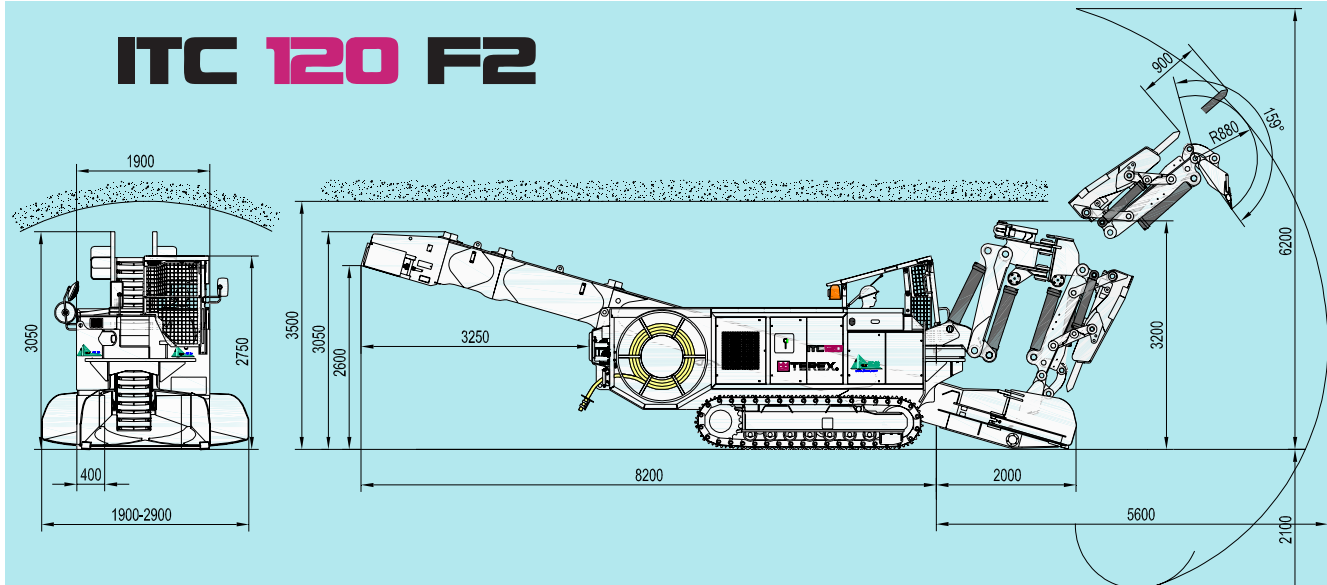

Technical data ITC 120 – F2

Drive units

Electro-hydraulic and Diesel-hydraulic power packs each with a separate pump units
 Electric drive for emission-free work at the face
 Air-cooled electric motor, Power at 400 Volt , 50 Hz 55 kW
 Diesel drive for travelling and operation without electrical supply
 Water-cooled diesel engine, Deutz TCD2012 L04 2V
 Power rating at 2,000 r.p.m 74 kW
 Diesel engine complies with emission standard Tier 3

Electrical system

Total installed power 60 kW
 Voltage (standard) 400 V - 50 Hz AC
 Control voltage 24 V DC
 Electrical system acc. to EN 60529 (IP54)
 Cable reel hydraulically driven with 75 m
 Cable cross section at 400 V - 50 Hz 3x50+3x10 mm²

Operator's cab

FOPS-Operator's cab gives all-round visibility, and front protection grill.
 Roof foldable for transport
 CE conformity incl. video monitoring system for the right and rear side with colour LCD in the cab.

Hydraulic system

Load Sense hydraulic system with combination of axial piston gear pump at each drive
 Pilot control system for all working functions
 Main operation by 2 joysticks in Euro standards
 Thermostatic controlled hydr. driven oil cooler
 Hydraulic pump flow rate 280 l/min
 Max. hydraulic operating pressure 280-380 bar
 Hydraulic oil capacity (incl. tank) 400 l

Hydraulic oil tank

300 l

Operating data (F2 boom equipment)

Minimal cross section approx. 9 m²
 Machine width 1'900 mm
 Maximal height 2'400-2'750 mm
 Transport height 2400 mm
 Length (dep. on equipment) ~10'000 mm
 Width of loading apron (adjust.) 1'900-2'900 mm
 Width of conveyor (internal) 620 mm
 Height of conveyor (internal) 650 mm
 Conveyor capacity approx. 150 m³/h
 Conveyor discharge height 1'800-2'500 mm
 Operating weight approx. 23,3 t

Boom Equipment F2

Excavation boom equipment for heading and loading, includes:

- King post with jib and swivel & tilt console
- Tool holder with a combination of hydraulic hammer and excavation / loading bucket
- Automatic lubrication system for the hammer
- Water spraying device (optional)
- Breakaway torque 100 kN
- Tear-out force over dipper stick 56 kN
- Lifting power (without working tool) 56 kN

Other Equipment

It is possible to attach a range of ancillary equipment, such as different bucket sizes, ripper tooth, pony truck, rubber plated conveyor, other voltage and frequency, other boom, quick hitch device, transverse cutting unit, soot particle filter, central lubrication device, extinguisher system, etc.

Further details of attachments and accessories available upon request.

Subject to modification without prior notice.